



CITY OF LONDON
FREEMEN'S SCHOOL

**SAMPLE SCHOLARSHIP
EXAMINATION PAPER**

For pupils currently in Year 8

SCIENCE
(BIOLOGY, CHEMISTRY, PHYSICS)

Time: 1 hour 15 minutes

You should spend no more than 25 minutes on each section.

Answer all questions in the spaces provided.

| | | |
|-------|---|--------|
| S1211 | ✓ | 13+SCI |
|-------|---|--------|

Candidates may be required to plot graphs and measure lengths and angles, so should bring a pen, pencil, ruler, rubber and protractor to the exam. The examination will mainly cover the topics taught in U3 (Year 7) and L4 (Year 8) at Freeman's. The topics are reproduced below.

Biology

- Cells
- Plant and Animal Reproduction
- Ecology
- Variation and Classification
- Human nutrition
- Genetics and inheritance

Chemistry

- Acids and Alkalis: acids and alkalis, indicators, pH, everyday applications and environmental problems
- Physical Separations and Changes: filtering, evaporation, distillation, fractional distillation, chromatography, states of matter, changes of state, effect of impurities, diffusion
- Chemical changes and corrosion: thermal decomposition, burning and oxidation, rusting, precipitates and effervescence
- Elements, Compounds and Mixtures: atoms and symbols for elements, compounds/mixtures, interpretation of formulae and particle diagrams

Physics

- Forces: their effects, electromagnets, Hooke's Law, pressure and moments
- Density
- Energy changes and efficiency
- Electrical circuits
- Reflection and refraction of light
- General knowledge of satellites and the Solar System

Pupils wishing to attempt question practice should purchase any book of Key Stage 3 examination-style questions.

BIOLOGY

B1. The masses of a brother and sister were recorded during the years of their growth as follows.

| age in years | mass in kg. | |
|--------------|-------------|------|
| | boy | girl |
| birth | 4.5 | 3.5 |
| 2.5 | 15.5 | 13.6 |
| 5 | 20.0 | 15.5 |
| 7.5 | 24.1 | 22.5 |
| 10 | 32.7 | 27.7 |
| 12.5 | 38.6 | 40.9 |
| 15 | 59.1 | 50.5 |
| 17.5 | 64.5 | 54.1 |
| 20 | 65.9 | 54.9 |

a) Plot these figures on graph paper using one pair of axes. From the graph, answer the following questions. [6]

b) At what age was the girl heavier than her brother?
_____ [1]

c) Which child showed the greatest annual increase in mass?
_____ [1]

d) Between what ages did this greatest growth rate occur?
_____ [1]

e) What was this annual increase in mass?
_____ [1]

f) Give one reason for this maximum growth rate occurring in this child at this age.
_____ [2]

g) What was the increase in mass per year at the time of the slowest growth rate in either child before the age of 13?
_____ [1]

B2. The diagram illustrates two important processes carried out by living organisms.

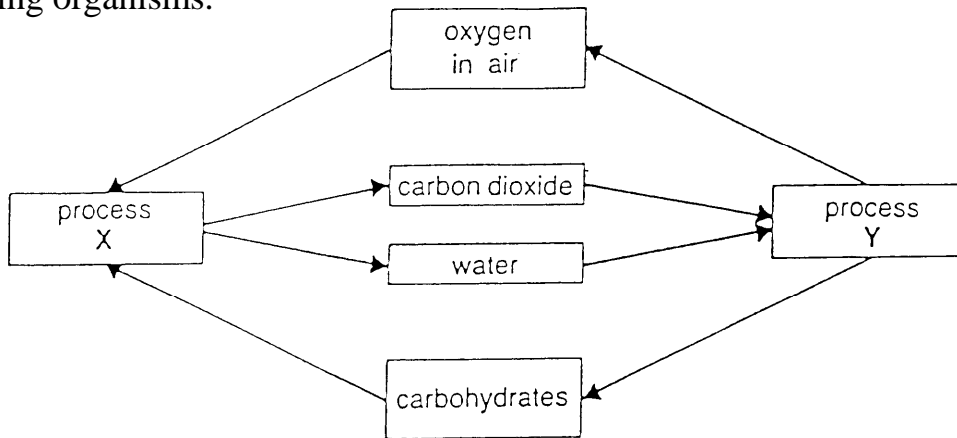

- a) [i] Process **X** is carried out by all living organisms.
Name this process.
- _____ [1]
- [ii] Why is this process important to all living cells?
- _____ [2]
- [iii] Which gas is used up in process **X** ?
- _____ [1]
- [iv] Which gas is produced in process **X** ?
- _____ [1]
- [v] Process **Y** results in the production of carbohydrates.
Name process **Y**.
- _____ [1]
- [vi] Which group of organisms carry out process **Y** ?
- _____ [1]
- [vii] Give two reasons why process **Y** is important to all living things.
- _____
- _____ [2]

B2. b) The pie chart represents the proportions of three common gases found in normal air.

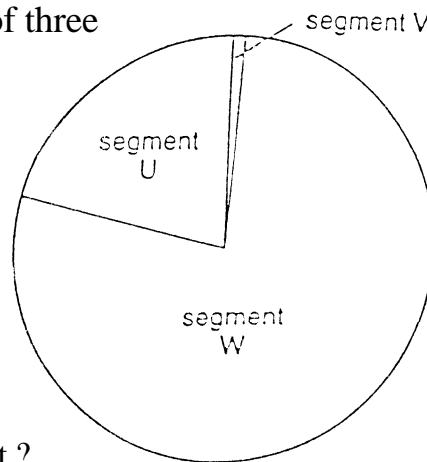

[i] Which segment does oxygen represent ?

_____ [1]

[ii] Which segment does carbon dioxide represent?

_____ [1]

[iii] Name one normal component of air not represented on this chart.

_____ [1]

[iv] Why is it difficult to show this component on a chart of this kind?

_____ [2]

c) Explain with reasons how the composition of air samples would vary from that shown in the pie chart if the samples were collected from the air above

[i] a bonfire.

_____ [3]

[ii] a wheat field on a hot sunny day in early summer.

_____ [3]

CHEMISTRY

Answer ALL questions in the spaces provided.

- C1. You are given a mixture of powdered limestone which is insoluble in water, and salt, which is soluble in water. Describe and explain what you would do in order to obtain separate samples of salt and limestone from the mixture.

[4]

- C2. The diagrams labelled A and C represent particles in two states of matter.

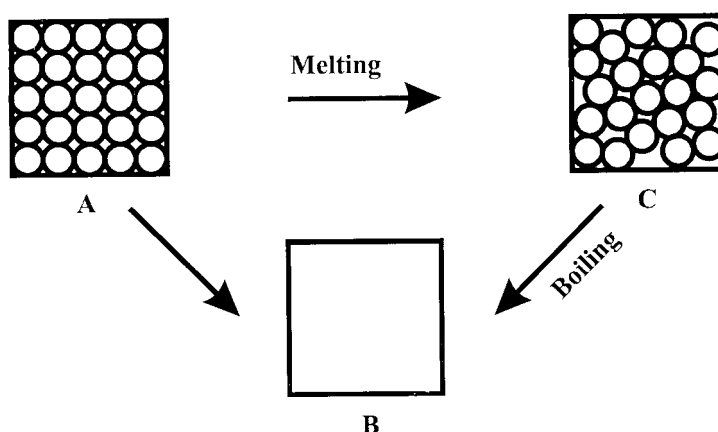

- a] Complete the diagram labelled B to show the arrangement of particles in this state.

C2. b] The particles in C are in the liquid state. In what state are the particles in A ?

c] How does the movement of particles in state C differ from state A?

d] How could state C be converted to state A ?

e] Name the process when state A is converted to state B.

_____ [5]

C3. a] Sometimes the lettering on gravestones becomes blurred. What process has occurred?

b] Name 2 factors that could cause the process to take place.

1. _____

2. _____ [3]

C4. An acid solution and alkaline solution were mixed in the volumes given in the table and the resulting solutions were tested with universal indicator. One mixture was neutral (pH 7), one had a pH value of 13 and the third had a pH value of 1.

a) Complete the following table

| Volume of acid (cm ³) | Volume of alkali (cm ³) | pH value |
|-----------------------------------|-------------------------------------|----------|
| 20 | 13 | |
| 20 | 15 | |
| 20 | 17 | |

[3]

b) Was the original acid or the original alkali more concentrated?

_____ [1]

c) State the colour that Universal indicator would go in

acidic solution _____

neutral solution _____

alkaline solution _____

[2]

d) Give an example of a neutralisation reaction that takes place outside the laboratory. Explain what is used, and why.

_____ [3]

e] A neutralisation reaction resulted in the formation of a compound with the formula $\text{Ca}(\text{NO}_3)_2$.

i) What is the chemical name of $\text{Ca}(\text{NO}_3)_2$?

ii) How many elements are there combined in the formula?

[2]

C5. Ben put a beaker weighing 50 g on a balance. He added 50 g of dilute hydrochloric acid and 2.5 g of calcium carbonate to the beaker. The total mass of the beaker and its contents was 102.5 g.

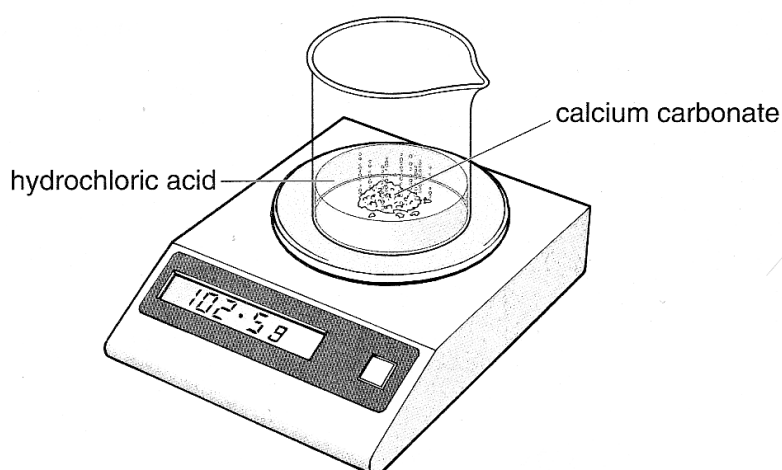

a] The Hydrochloric acid reacted with the calcium carbonate. How could Ben tell that a chemical reaction was taking place in the beaker?

_____ [1]

b] The word equation for the reaction which took place is:

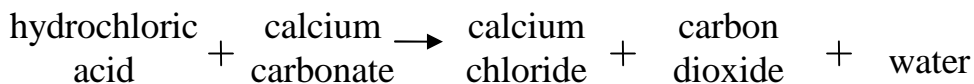

When the reaction stopped, the total mass had decreased from 102.5 g to 101.4 g.

Some water had evaporated from the beaker.

What else caused the drop in mass?

Use the word equation to help you answer the question.

[1]

c] When the reaction stopped, Ben tested the contents of the beaker with universal indicator paper. The calcium carbonate had neutralised the acid.

What is the colour of universal indicator paper in a neutral solution?

[1]

d] Which **two** materials in the list below are mainly calcium carbonate?

Tick the correct boxes.

[2]

coal

glass

limestone

marble

sandstone

C6. a] When alcohol burns heat energy is released.

What word describes a reaction when heat is given out?

_____ [1]

b] When the alcohol burns carbon dioxide and water form.
What does this tell you about the elements in alcohol?

_____ [1]

c] What chemical would you use to show water was formed?

_____ [1]

d] When coal is burnt several products are formed.
One or more of these can be considered to be a pollutant of the
air.

[i] Name one pollutant.

[ii] State why it is harmful to the environment.

_____ [2]

PHYSICS

- P1. The diagram shows a crane lifting a load. The counterweight and the load are balanced.

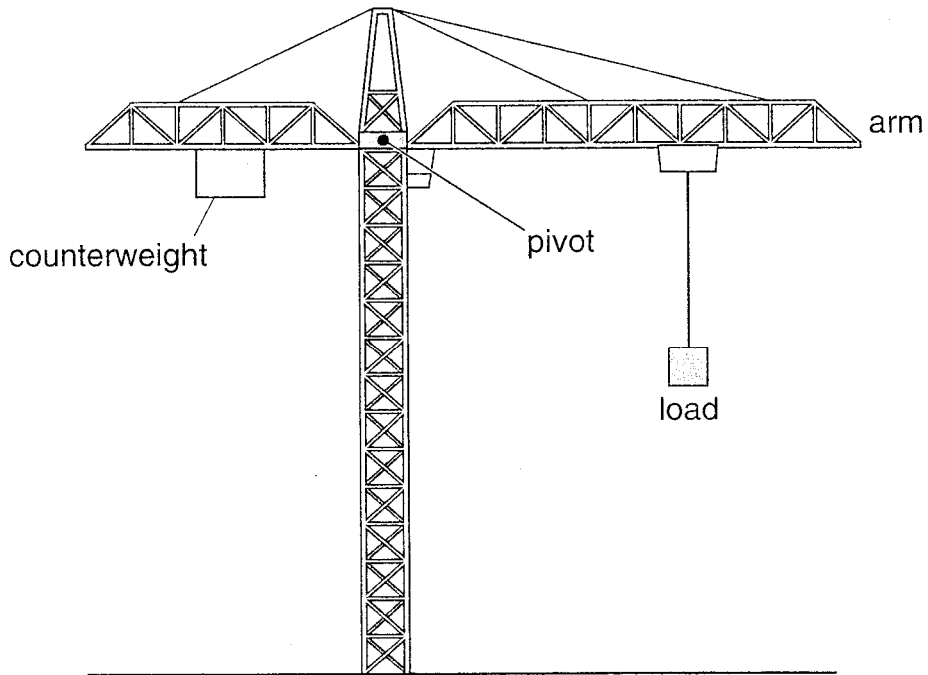

- (a) The load is moved away from the pivot, to the right.
- (i) What happens to the turning moment produced by the load?

_____ [1]

- (ii) What should happen to the counterweight to keep the arm balanced?

_____ [1]

(b) A load of 5000 N is placed 8 m from the pivot.

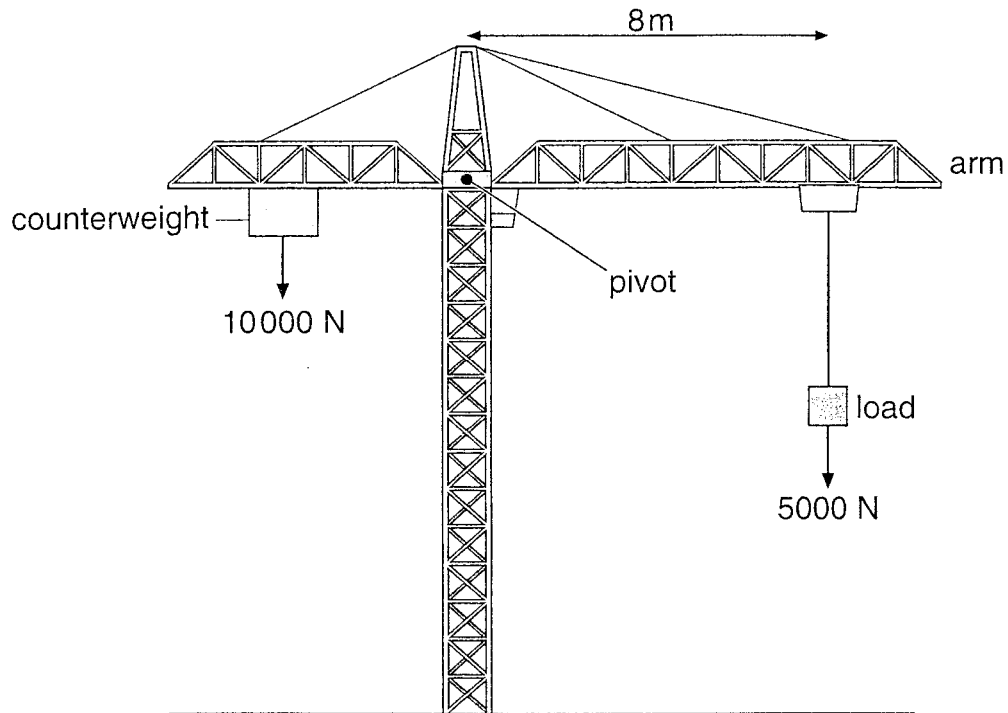

(i) What is the turning moment of the load? Give the unit.

_____ [2]

(ii) How far from the pivot must 10 000 N counterweight be placed in order to balance the load?

_____ m [1]

(iii) The counterweight is placed 3 m from the pivot. What load could now be balanced 8 m from the pivot?

_____ [1]
_____ N

P2. In 1610, the Italian scientist, Galileo, observed four bright moons near Jupiter. Each night the moons moved.

- (a) (i) The Sun and stars are light sources, and the planets are seen by reflected light. Explain how we can see the moons of Jupiter.

[2]

- (ii) The four moons are approximately the same distance from the Earth. However, they do **not** have the same brightness. Suggest **one** reason for this.

[1]

- (b) The table shows the distances of the four moons from the centre of Jupiter, and the times of their orbits. Europa's distance has been left out.

| name of moon | distance from Jupiter, in millions of km | time for one orbit, in Earth days |
|--------------|--|-----------------------------------|
| Io | 0.42 | 1.8 |
| Europa | | 3.6 |
| Ganymede | 1.07 | 7.2 |
| Callisto | 1.88 | 16.7 |

The graph was plotted using the information in the table.

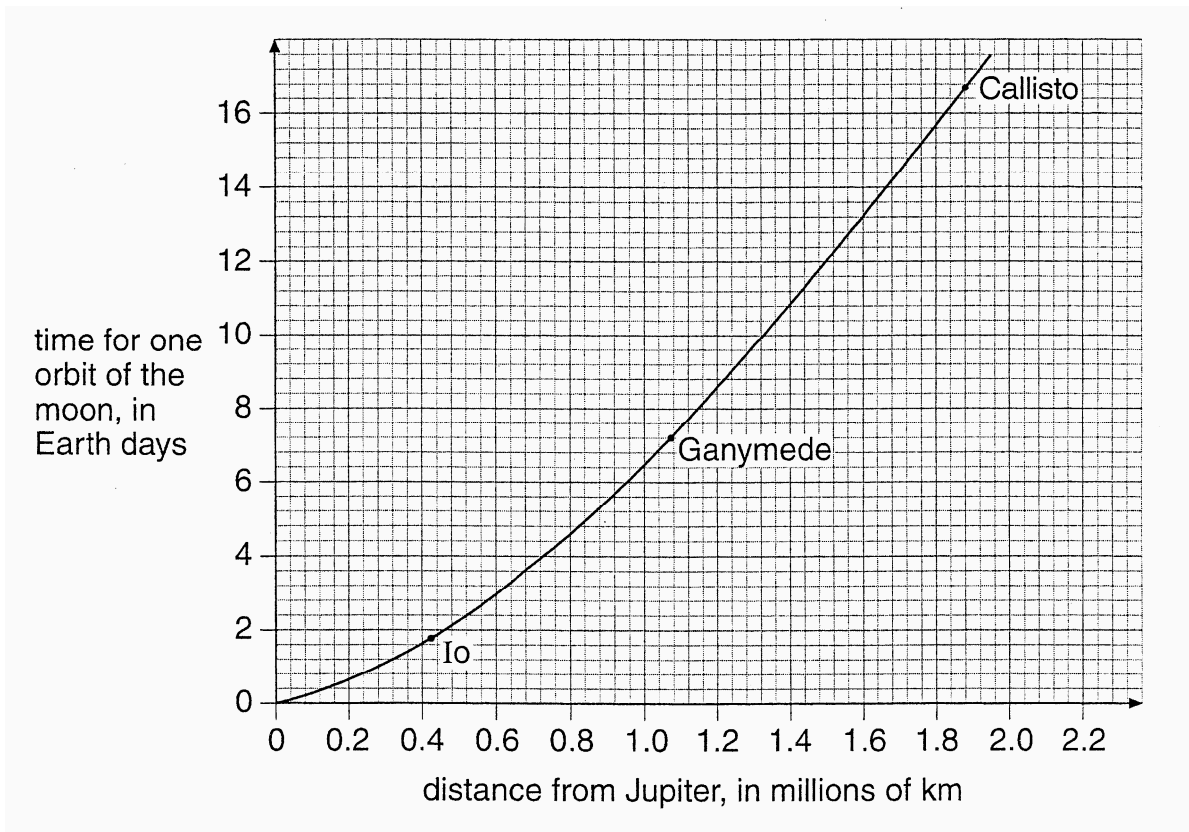

Use the graph to estimate Europa's distance from Jupiter.

[1]

_____ millions of km

(c) Galileo realised that Jupiter and its moons formed a model of our Solar System. In the model:

What did Jupiter represent? _____ [1]

What did the moons represent? _____

- P3. Karen wants to pump up her car tyre.
Her pump has a piston with an area of 7 cm^2 .

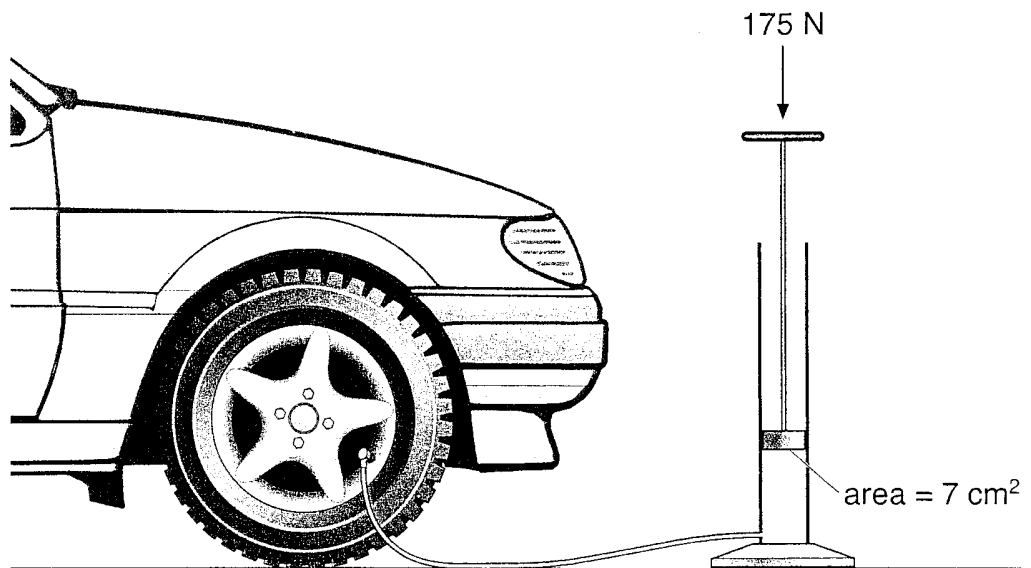

Karen pushes the handle down with a force of 175 N.

- (a) What pressure does she exert on the air in the pump?

_____ [2]
_____ N/cm^2

- (b) The air pressure in the tyre is 27 N/cm^2 .
What pressure would be needed **in the pump** in order to pump more air into the tyre?

_____ [1]

- (c) Another of Karen's car tyres exerts a pressure of 30 N/cm^2 on the road. The area of the tyre in contact with the road is 95 cm^2 .
What is the force exerted by the tyre on the road?

_____ [1]

- P4. A teacher set up the following apparatus behind a safety screen. She placed 1 g of icing sugar in the end of the rubber tubing inside the tin, as shown below.

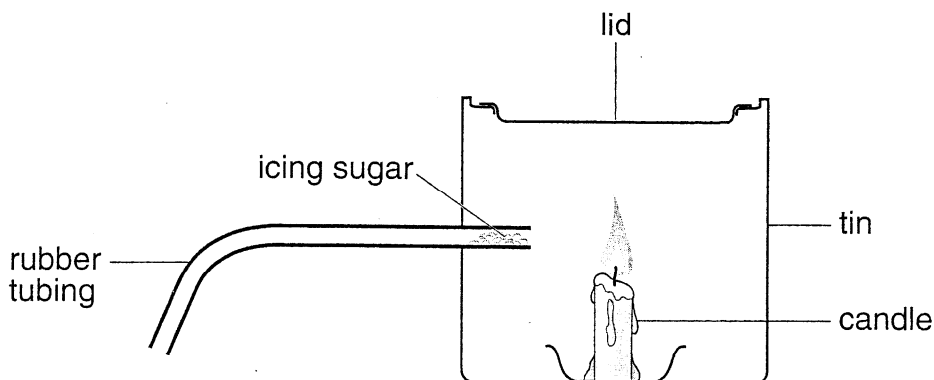

The teacher blew through the other end of the rubber tubing. The icing sugar came into contact with the flame. There was a loud explosion and the lid was blown off the tin.

- (a) Complete the following sentence describing the energy changes which took place.

_____ energy in the icing sugar changed to [3]
_____ energy and _____ energy.

- (b) As a result of the explosion, the lid of the tin was pushed off. Explain what had happened to the gas molecules inside the tin to make this happen.

_____ [2]

P5. The diagram shows two dodgem cars at a fairground. The circuit symbols for the motor and the pedal for each car are shown on the diagram.

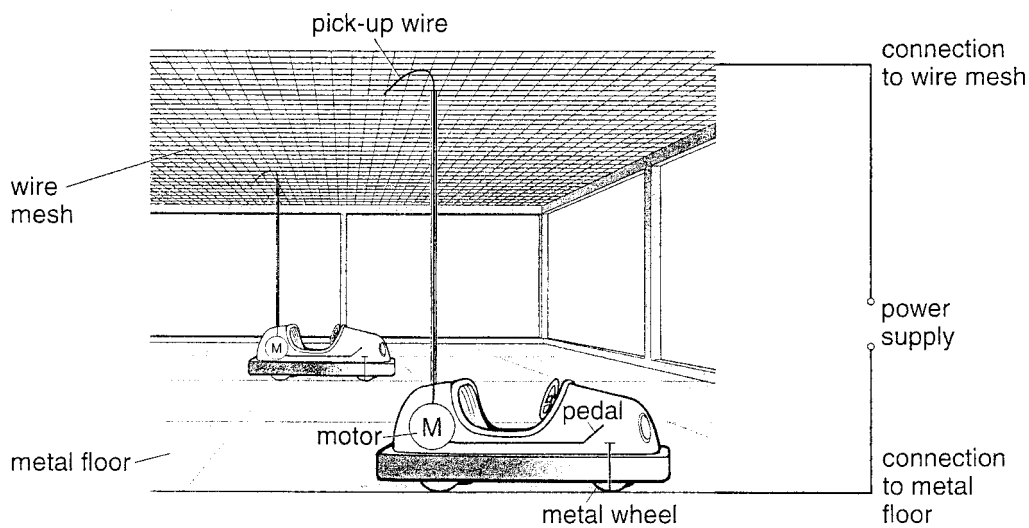

(a) Complete the following sentence.

Each dodgem is connected to the power supply through the _____ which is in contact with the wire mesh, and through the _____ which is in contact with the metal floor.

[1]

(b) Dodgem cars are connected using parallel circuits. Complete the circuit diagram below for the **two** dodgem cars.

Use **two** motor symbols, $\textcircled{\text{M}}$, and **two** switch symbols.

The power supply for the circuit has been drawn for you.

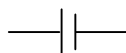

[2]

- (c) Even when the power supply is switched on, the dodgem will **not** move until the pedal is pressed. Give the reason for this.

[1]

- (d) A man looks after the dodgem cars during the rides. Why does the man **not** get an electric shock as he walks across the metal floor?

[1]

- (e) During one ride, the two dodgem cars are running. The pick-up wire on one car snaps off. Describe how this affects:

- (i) the dodgem car with the broken pick-up wire;

[1]

- (ii) the other dodgem car.

[1]

P6. The picture shows a man called Aristotle. He lived in Greece over 2000 years ago.



Aristotle said that the heavier an object is, the faster it will fall to the ground.

(a) The drawings below show a bowling ball, a cricket ball and a ping-pong ball. Lila dropped them all at the same time from the same height.

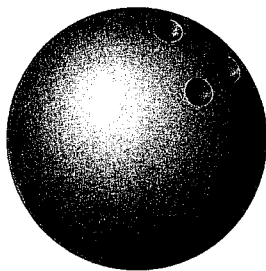

bowling ball
mass=5000 g

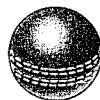

cricket ball
mass=160 g



ping-pong ball
mass=2.5 g

If Aristotle was correct, which of the three balls would you expect to reach the ground first? Give the reason for your answer.

[1]

(b) Joe said it would be a fairer test if Lila had only used a cricket ball and a hollow plastic ball as shown below.



cricket ball
mass=160 g



hollow plastic ball
mass=56 g

Why was Joe correct?

[1]

(c) About 400 years ago in Italy, a man called Galileo had a different idea. He said that all objects dropped from the same height would reach the ground at the same time.

(i) Lila dropped a hammer and a feather at the same time from the same height.

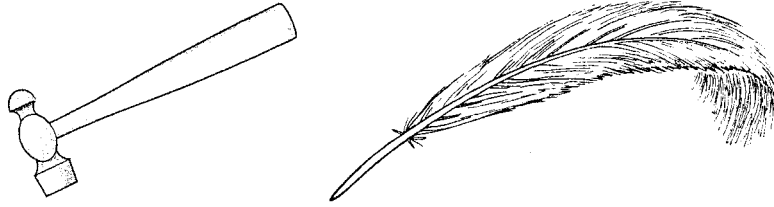

If Galileo was correct which, if either, would reach the ground first?

_____ [1]

(ii) Gravity acts on both the hammer and the feather as they fall. Give the name of **one** other force which acts on them as they fall.

_____ [1]

(iii) An astronaut on the moon dropped a hammer and a feather at the same time from the same height.



How would the result of the astronaut's experiment on the Moon be different from Lila's experiment on the Earth?

Explain your answer.

_____ [2]